

# SC

## MULTIPROCESADOR



**50**  
1973 - 2023  
ANNIVERSARY



# SC

APPLICACIONES



# MULTIPROCESADOR

## MULTIPROCESADOR

L'SC è un'attrezzatura multifunzionale che consente di affrontare tutti i tipi di demolizione, da quella Primaria, a quella Secondaria, a quella Selettiva (Strip out).

È costituito da un corpo principale dotato di due cilindri al quale possono essere montate diverse tipologie di chele destinate alle più svariate attività di abbattimento, di taglio, di frantumazione e di riciclaggio di strutture e manufatti in cemento e ferro.

La versatilità dell'SC consente di lavorare su diversi tipi di materiali, dal meno resistente al più tenace, garantendo la massima efficacia in termini di operatività e di tempi di lavoro.

La sua tecnologia contribuisce a ridurre l'impatto ambientale e ad aumentare la produttività generale delle operazioni di demolizione. Con l'SC di VTN, gli operatori possono lavorare con maggior sicurezza, precisione e flessibilità, riducendo l'uso di attrezzature ausiliarie.

- › 4 Kit chele intercambiabili
- › Elevata coppia di rotazione a 360°
- › Cicli di lavoro brevi ed affidabili (Speed Valve)
- › Cilindri rovesciati e completamente protetti
- › Denti di frantumazione e lame di taglio reversibili e intercambiabili
- › Impianto idraulico facilmente accessibile
- › Ridotta manutenzione

## MULTIPROCESSOR

The SC is a multi-processor that can tackle all types of demolition, from Primary to Secondary and Selective (Strip out).

It consists of a main body equipped with two cylinders to which different types of jaws can be fitted for the most diverse demolition activities, crushing, cutting, and recycling of concrete and steel structures and artefacts.

The SC's versatility allows it to work on different types of materials, from the least resistant to the more tenacious, ensuring the maximum efficiency in terms of operation and working time.

Its technology helps to reduce the environmental impact and increase the overall productivity of demolition operations. With the VTN SC, operators can work with greater safety, precision, and flexibility, reducing the use of auxiliary equipment.

- › 4 interchangeable jaw kits
- › Compact design 360° rotation
- › Quick and reliable working cycles (Speed Valve)
- › Reversed and fully protected cylinders
- › Reversible and interchangeable crushing teeth and cutting blades
- › Easily accessible hydraulic system
- › Low maintenance

## MULTIPROCESADOR

El SC es un equipo multifuncional que le permite abordar todo tipo de demolición, desde la Primaria, la Secundaria hasta la Selectiva (Strip out).

Consta de un cuerpo principal dotado de dos cilindros a los que se le pueden montar distintos tipos de mandíbulas, destinadas a las más variada actividad, corte, trituración, reciclaje de estructuras tanto de hormigón como de hierro.

La versatilidad del SC permite trabajar sobre diferentes tipos de materiales, desde los menos resistentes hasta los más duros, asegurando la máxima eficacia en cuanto a funcionamiento y tiempos de trabajo.

Su tecnología ayuda a reducir el impacto medioambiental y aumentar la productividad general de las operaciones de demolición. Con el SC de VTN, los operarios pueden trabajar con mayor seguridad, precisión y flexibilidad, reduciendo el uso de equipos auxiliares.

- › 4 kits de mandíbulas intercambiables
- › Alto par de rotación de 360°
- › Ciclos de trabajo cortos y fiables (Speed Valve)
- › Cilindros invertidos y totalmente protegidos
- › Dientes trituradores y cuchillas de corte reversibles e intercambiables
- › Instalación hidráulica de fácil acceso
- › Mantenimiento reducido





# DEMOLITION

	t min/max · lb min/max		
SC140	13	14 / 23	24
	29000	31000/51000	53000
SC180	19	20 / 30	32
	41000	44000/66000	70000
SC250	25	26 / 38	40
	55000	57000/84000	88000

Model	SC140	SC180	SC250
°	360	360	360
°	360	360	360
l/min	20 / 30	20 / 30	20 / 30
gal/min	5 / 7	5 / 7	5 / 7
bar	120	120	120
psi	1739	1739	1739
l/min	170 / 210	170 / 210	250 / 300
gal/min	44 / 55	44 / 55	65 / 79
bar	350	350	350
psi	5072	5072	5072
kg	1030	1195	1630
lb	2289	2656	3622



A

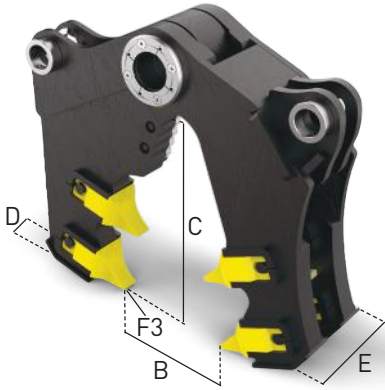

## D Crusher



Model		SC140	SC180	SC250
Jaws type		D	D	D
<b>A</b>	mm	700	2123	2410
	in	27,6	83,6	94,9
<b>B</b>	mm	700	780	960
	in	27,6	30,7	37,8
<b>C</b>	mm	650	730	900
	in	25,6	28,7	35,4
<b>D</b>	mm	143	137	143
	in	5,6	5,4	5,6
<b>E</b>	mm	310	363	373
	in	12,2	14,3	14,7 t
<b>F3</b>		51	62	82
	Sh ton	56	68	90
Total	kg	1560	1985	2680
	lb	3467	4411	5956
Jaws	kg	530	790	1050
	lb	1178	1756	2333
●	mm	30	30	40
	in	1,2	1,2	1,6

## R Combi



Model		SC140	SC180	SC250
Jaws type		R	R	R
<b>A</b>	mm	1857	2117	2442
	in	73,1	83,3	96,1
<b>B</b>	mm	700	780	870
	in	28	31	34
<b>C/C1</b>	mm	650 / 340	730 / 430	870 / 570
	in	25 / 13	28 / 16	34 / 22
<b>D</b>	mm	90	137	137
	in	3,5	5,4	5,4
<b>E</b>	mm	320	390	475
	in	12,6	15,4	18,7
<b>F3</b>	t	52	62	82
	Sh ton	57	68	90
Total	kg	1500	1910	2870
	lb	3333	4244	6378
Jaws	kg	470	670	1240
	lb	1044	1489	2756
●	mm	30	35	40
	in	1,2	1,4	1,6
IPE 	mm	120	200	240
	in	4,7	7,9	9,4
HEA 	mm	100	150	180
	in	3,9	5,9	7,1

# DEMOLITION

## S Shear

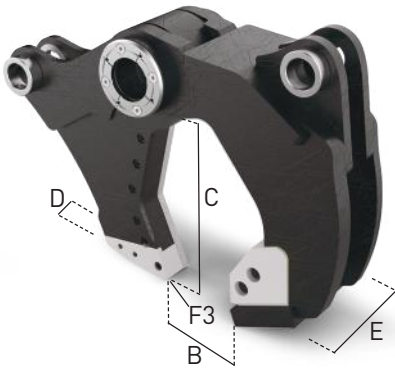

Model		SC140	SC180	SC250
Jaws type		S	S	S
<b>A</b>	mm	1170	1960	2226
	in	46,1	77,2	87,6
<b>B</b>	mm	300	360	485
	in	11,8	14,2	19,1
<b>C</b>	mm	400	510	570
	in	15,7	20,1	22,4
<b>D</b>	mm	107	107	107
	in	4,2	4,2	4,2
<b>E</b>	mm	269	289	355
	in	10,6	11,4	14,0
<b>F3</b>	t	71	83	111
	Sh ton	78	91	122
<b>Total</b>	kg	1450	1795	0
	lb	3222	3989	0
<b>Jaws</b>	kg	420	600	825
	lb	933	1333	1833
●	mm	40	45	50
	in	1,6	1,8	2,0
—	mm	10	10	15
	in	0,0	0,0	0,0
<b>IPE I</b>	mm	180	200	300
	in	7,1	7,9	11,8
<b>HEA</b>	mm	140	160	220
	in	5,5	6,3	8,7

## CH Swiss



Model		SC140	SC180	SC250
Jaws type		CH	CH	CH
<b>A</b>	mm	1892	2037	2357
	in	74,5	80,2	92,8
<b>B</b>	mm	590	625	770
	in	23,2	24,6	30,31
<b>C</b>	mm	550	595	755
	in	21,7	23,4	29,7
<b>D</b>	mm	145	145	262
	in	5,7	5,7	10,3
<b>E</b>	mm	390	405	420
	in	15,4	15,9	16,5
<b>F3</b>	t	53	74	89
	Sh ton	58	81	98
<b>Total</b>	kg	1630	1890	2780
	lb	3622	4200	6178
<b>Jaws</b>	kg	600	695	1150
	lb	1333	1544	2556
●	mm	30	35	40
	in	1,2	1,4	1,6

**VTN EUROPE S.p.A.**

Via dell'Artigianato 41/43  
36026 Cagnano di Pojana Maggiore · VI · Italy

T +39 0444.864.211

[vtneurope.com](http://vtneurope.com)

